

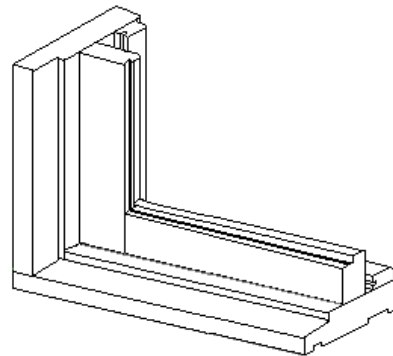

## DESIGN FEATURES

- Successfully tested to comply with Australian standard AS 2047
- Key type cam handles supplied as standard for maximum security.
- Opening sashes operate on large diameter wheels ensuring smooth operation.
- This window type will couple to all of the cedar range vertically. Glass is sealed from both sides to prevent leakage.
- Cedar sliding windows are also able to be fabricated as four light sliders.
- Wide top & bottom rails give the window a bold appearance.
- Fixed sill has a tapered design to assist drainage.
- 168mm sill available.
- Flyscreens are available in timber or aluminium frames.



700/150Pa Wind/Water Rating

Maximum Overall Height	1538mm - without transom
Maximum Overall Width	2378mm - 2 light
Maximum Glass Width	16mm - with adaptors

Subject to individual site conditions. Contact HANLON WINDOWS Technical Support for more information.



AWA / WERS RATED PRODUCT



ENHANCED ACOUSTIC PERFORMANCE



PRODUCT INFORMATION AVAILABLE AT  
[WWW.HANLONWINDOWS.COM.AU](http://WWW.HANLONWINDOWS.COM.AU)



SPECIFIER ASSISTANCE AVAILABLE

## TYPICAL CONFIGURATIONS

