

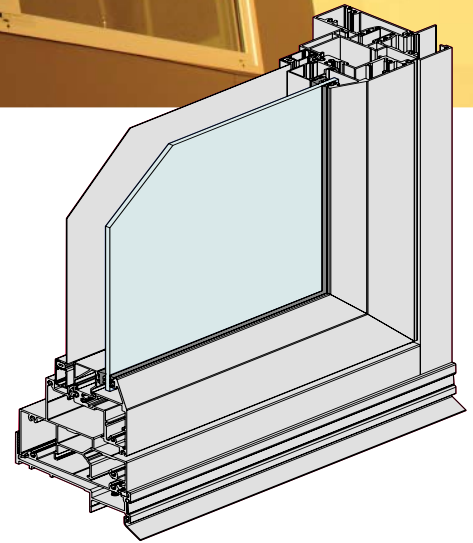

DESIGN FEATURES

- This high performance awning and casement window has been designed to accept Truth™ Hardware. This allows us to offer very large casements and awnings fitted with scissor type winders with jamb to stile latches that secure the sashes in the closed position.
- The extra strong sashes allow large sash windows to be fabricated for high wind load areas. Successfully tested to resist 450Pa water.
- Fixed sidelights/lowlights and highlights can be single or double glazed.
- The perimeter frame has been designed to make installation into brick veneer and cavity brick easier with built-in nailing fins (weather bars). The sub-sill that comes with this window also has a built-in nailing fin.
- The Truth™ hardware can resist very high negative wind loads with the use of winders and side latches.
- Series 467 accepts flyscreens that tuck into head and sill recess.
- On casements it's possible to clean the external glass face when the sash is in the 90° open position.
- The nailing fin frame has several important features that are worth highlighting:
 - Built-in nailing fin is more waterproof.
 - Frame accepts height adjustable galvanised M.S. building-in lug.
 - Sub-sill has external recess to accept PVC sill flap.
- Sub-sills are standard on Series 467, see the illustration on the back page.



Maximum Panel Height	2100mm
Maximum Panel Width	1200mm
Maximum Glass Thickness	≤ 24mm

Subject to individual site conditions. Contact AWS Technical Support for more information.



WERS RATED PRODUCT



ENHANCED ACOUSTIC PERFORMANCE



3D & 2D CAD FILES AVAILABLE



PRODUCT INFORMATION AVAILABLE AT
WWW.AWSCOMMERCIAL.COM.AU



SPECIFIER ASSISTANCE AVAILABLE



A major feature with Series 467 is the frame with in-built nailing fin (weather bar). This makes installation into cavity brick with height adjustable building-in lugs and into brick veneer walls with timber reveals as shown above possible. The standard jamb is 102 x 30mm as shown above, we also offer 102 x 44mm jamb and again with the nailing fin feature. Nailing fins may not sound that important but this built-in weather bar is what stops water traveling from the outer brick skin to the inner wall. The sashes are 50mm thick and will accept glass from 4mm to 24mm thick.



The Truth scissor winder is designed to support heavy sashes in the open and closed positions. The handle folds back into the winder body when not in use, as shown above.

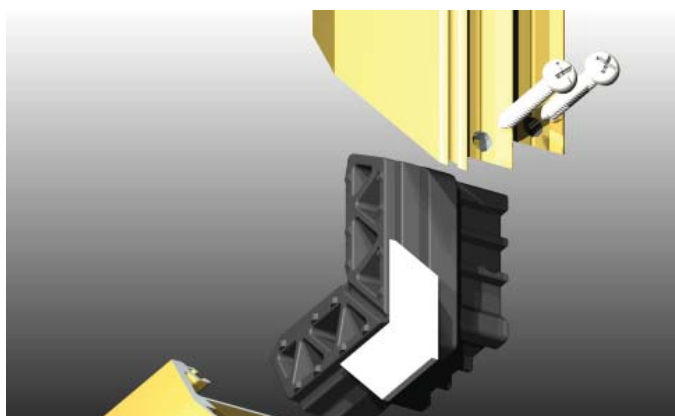

The key to making strong sashes is fitting heavy duty corner stakes. You won't see this feature but it's good to know the corners will stay tight even under extreme conditions.

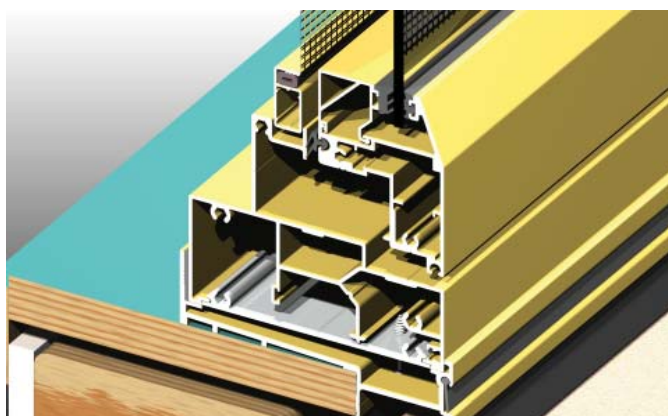

Sub-sills are standard on Series 467. The sub-sill has several significant features:

- Full flashing tray guides any water that gets into the window back to the outside.
- Our custom sub-sill designed for cavity brick and brick veneer construction has built-in nailing fin to allow sill timber reveal fixing.
- The PVC flap on the outer edge of the sub-sill caters for stud wall settlement on brick veneer construction.
- Sub-sill fitted with co-extruded Santoprene drain hole cover flap to prevent blow back under extreme situations.
- Sub-sill is also stop ended to guide water back to the front.



2D & 3D CAD FILES AVAILABLE
GO TO: www.awscommercial.com.au >
CAD & Revit 3D Files
CAD file: DWG or DXF AWS_467_1



MORE INFORMATION
For the latest updates regarding this product visit our web site
www.awscommercial.com.au