

Series 729 Thermally Broken Hinged Door



Series 729 Thermally Broken Hinged Door

DATE: AUG 20
 REPLACES: NOV 09
 SCALE: NOT TO SCALE

KEY FEATURES / PERFORMANCE CHARACTERISTICS

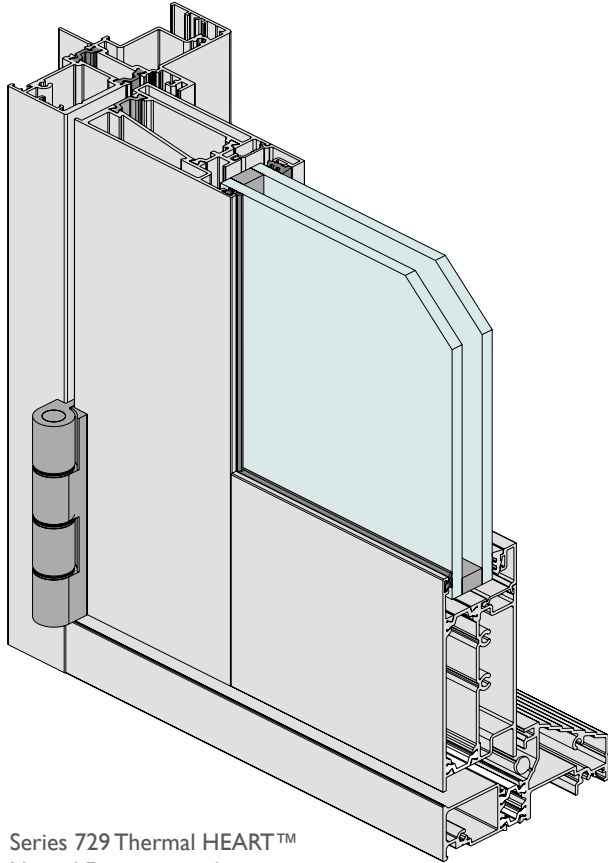

Series 729 Thermal HEART™
Hinged Door internal view

- Series 729 incorporates ThermalHEART™ technology giving a true wide thermal break between the outside and inside faces. WERS (Window Energy Rating System) data shows that using the same IGU in a ThermalHEART™ door is 32% more efficient than a standard non-thermally broken door.
- A major advantage with ThermalHEART™ in cold climates is the reduction in internal condensation. This saves potential damage to timber reveals and floor finishes.
- ThermalHEART™ is also suitable for hot climates - ThermalHEART™ Windows and Doors will help to reduce the cooling load on air conditioning units in hot climates.
- We offer ThermalHEART™ in a range of stocked colours including dual colour ClearMIST™ (Clear anodised external with SurfMist powder coat internal).
- The doors have been tested for compliance with the relevant Australian Standards and achieved a high water resistance of 380Pa for external swing doors and 150Pa water resistance for internal opening doors, this makes the product suitable for most residential applications.
- Low air infiltration, makes the product suitable for air conditioned buildings.
- The extra strong door stiles allow over size door panels to be fabricated, refer Pascal rating tables later in these notes.
- Sharp square external glazing beads are standard.
- 100mm frame and transom have a soft 2mm internal radius.
- Can be fitted with Centor retractable flyscreen.

Maximum Panel Height*	2600mm
Maximum Panel Width*	900mm
Maximum Glass Thickness	≤ 32mm

* Subject to individual site conditions and wind loads. Contact AWS Technical Support for more information, e-mail techsupport@awsaustralia.com.au

TYPICAL CONFIGURATIONS

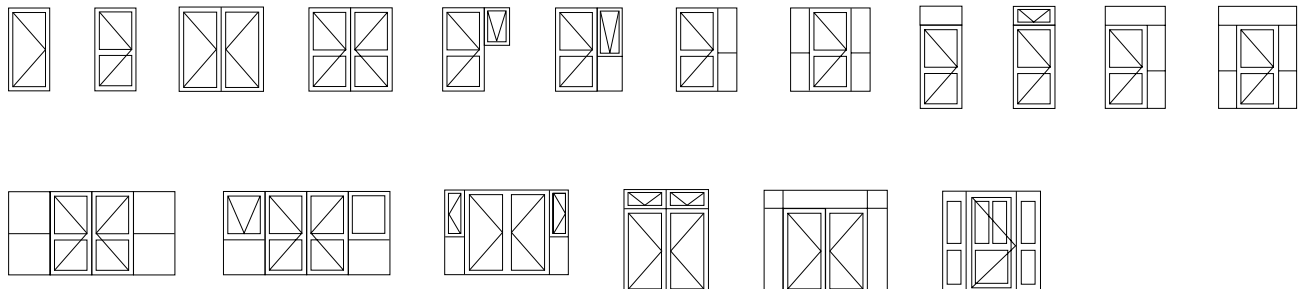

Series 729

Thermally Broken Hinged Door

DATE: AUG 20
 REPLACES: NOV 09
 SCALE: NOT TO SCALE



SOUND REDUCTION

A number of glass combinations have been tested in a similar door system. Panel stiles were fitted with co-extruded Santoprene fin seals.

Glass Description		
6.38mm Laminated glass	31dB(A)	RW32
19mm Insulating glass unit	32dB(A)	RW33



WERS RATINGS

Double Glazed

Glass Description	COOLING	HEATING	Uw	SHGCw	Tvw	Inf
4AZ/10Gap/4EA	67%	39%	2.8	0.26	0.38	0.64
4Clr/10Ar/4EA	55%	50%	2.6	0.44	0.45	0.64
4Clr/10Gap/4Clr	50%	44%	3.3	0.47	0.49	0.64
4Clr/10Gap/4EA	55%	48%	2.8	0.44	0.45	0.64
5Clr/8Gap/5Clr	51%	43%	3.3	0.46	0.48	0.64
5EG/8Ar/5EA	67%	39%	2.7	0.26	0.37	0.64
6Clr/12Gap/6Clr	52%	44%	3.2	0.44	0.47	0.64
6EG/12Gap/6Clr	65%	33%	3.2	0.26	0.35	0.64
6Clr/12Gap/6EA	56%	48%	2.8	0.42	0.44	0.64
6EG/12Gap/6EA	69%	36%	2.8	0.23	0.33	0.64



2D & 3D CAD FILES AVAILABLE

GO TO: www.specifyaws.com.au

CAD file: DWG and PDF 729.HNGE



MORE INFORMATION

For the latest updates regarding this product visit our website

www.specifyaws.com.au

HOW TO SPECIFY

SYSTEM NAME

Vantage Series 729 Thermal HEART™
 Hinged DOOR

FINISH

Powder Coat

Anodised

COLOUR

Select from the ThermalHEART range of approved powder coat or anodising colours. Dual colour options available.

GLASS

Specify thickness ≤ 32mm Specify thermal performance where applicable (Uv & SHGC)

Specify acoustic performance where applicable (RW)

HARDWARE

Refer to hardware selection guide for compatible options



Specification Assistance

Need help specifying this product? email techsupport@awsaustralia.com.au and our qualified technical advisors will assist you with product selection and specification for your project.



Series 729

Thermally Broken Hinged Door

DATE: AUG 20
 REPLACES: NOV 09
 SCALE: NOT TO SCALE

SPECIFIERS CHECKLIST

Not all hinged doors are the same. If you want your doors to perform, keep the elements on the outside where they belong and operate smoothly for years to come, there are some things you should check/compare when choosing your supplier - compare us with the others.

FEATURE	Series 729	Opposition
True thermal break The Vantage Series 729 hinged door frame and panels are thermally broken.	YES	
Thick Insulating Glass Units (IGU's) The Vantage Series 729 hinged door will accept very thick IGU's up to 32mm thick. Matching fixed sidelights and awning overlights will also accept glass up to 32mm thick.	YES	
Will the hinged door keep the water out - has it been tested? The Vantage Series 729 hinged door has been successfully tested to keep water out. Open out door will resist up to 380Pa of water. Open in door will resist up to 150Pa of water.	YES	
Is the product suitable for air-conditioned apartments? Very low air infiltration makes the product ideal for air-conditioned buildings.	YES	
Are the door stiles strong enough to support the glass? Doors are hinged off heavy duty double tubular jamb with thickened webs where hinges attach. If the jamb is not strong enough nothing you can do in the future will make the door perform. Many of our competitors hang doors off sections not much stronger than our window sections, this usually results in the doors dropping and/or the failure of hinge fixings.	YES	
Rebated door meeting stiles Rebated door stiles give flush appearance where two doors meet and provide superior weather protection. These rebated stiles ensure water is kept out.	YES	
Are the door panel sections strong enough? We have deliberately designed the door sections to suit high quality hardware and be capable of supporting the double glazing without sagging. There is no value hanging a flimsy door panel in the opening if it won't stand the test of time as hinged doors are subjected to far more abuse than sliding doors.	YES	
Are parliament type hinges available? Parliament hinges allow external swing doors to be opened up 180° back against the wall.	YES	
On pairs of doors is the lock keeper concealed? Concealed lock keeper specially designed to fit in the cavity on the leading edge of the "lazy side" door and eliminates unsightly holes milled in the aluminium for latch and lock bolt. This recessed keeper plus the rebated stile makes it extremely difficult for intruders to access the latch and bolt for forced entry.	YES	
High quality hardware Heavy duty custom hinges designed to suit the door and frame without having to fit shims etc. Custom lock keepers remove the need for ugly shims and cutouts in the stiles & frame. Specially designed backing plates at the four corner joints of the door. These take the "sloppiness" out of corner joints and make sure that the door stays rigid and square. Compare our door with others available and you will see what we mean about strength and rigidity. Co-extruded Santoprene door stop seals as standard. Custom colour matched or 316 marine grade stainless steel lever lock hardware available. High security Lever Compression Locking (4 point locking) standard on Series 729.	YES	

Series 729

Thermally Broken Hinged Door

DATE: AUG 20
REPLACES: NOV 09
SCALE: NOT TO SCALE

DESIGN FEATURES

We offer both external and internal opening hinged doors that have been designed to complement our other thermal products.

Series 729 incorporates ThermalHEART™ technology giving a true wide thermal break between the outside and inside faces. WERS (Window Energy Rating System) data shows that using the same IGU in a ThermalHEART™ door is 32% more efficient than a standard non-thermally broken door.

A major advantage with ThermalHEART™ in cold climates is the reduction in internal condensation. This saves potential damage to timber reveals and paint finishes.

ThermalHEART™ is also suitable for hot climates - Thermal Heart Windows and Doors will help to reduce the cooling load on air conditioning units in hot climates

We offer ThermalHEART™ in a range of colours (including dual colour) your local Vantage fabricator for details.

The doors have been tested for compliance with the relevant Australian Standards and achieved a high water resistance of 380Pa for external swing doors and 150Pa water resistance for internal opening doors, this makes the product suitable for most residential applications.

Low air infiltration, makes the product suitable for air conditioned buildings.

The extra strong door stiles allow over size door panels to be fabricated, refer Pascal rating tables later in these notes.

Sharp square external glazing beads are standard.

100mm frame and transom have a soft 2mm internal radius.

Doors can be fitted with a variety of custom lever sets (ICON™ or MIRO™) with Lever Compression Lock (LCL) motor as standard. After closing the door panel you can lift the handle to activate the compression feature. This throws bolts into head and sill and deploys the central locking bolt. The individual features of both furniture sets are shown later in this section.

ICON™ lever sets are only available in 316 Stainless steel finish.

The door frame is compatible (appearance, strength and performance) with the high performance ThermalHEART™ bi-fold doors and matches the ThermalHEART™ awning window. We have light and heavy 180° couplers that will join windows to doors without unsightly rivets or screws while maintaining the thermal break.

Fixed highlights/sidelights use the matching Series 726 fixed frame. The glazing beads are the same as adjoining door panels.

Panels are hung on heavy duty custom hinges, refer details later in this section.

We also offer custom parliament hinges for external swing doors that allow the panel to lay back against the wall, refer details later in this section.

Panels and sidelights will accept a variety of glass thicknesses from 4mm single panes to 32mm insulating glass units.

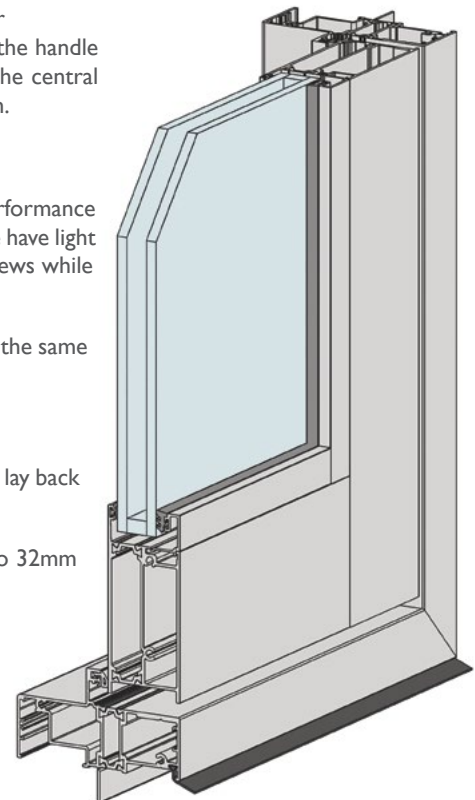
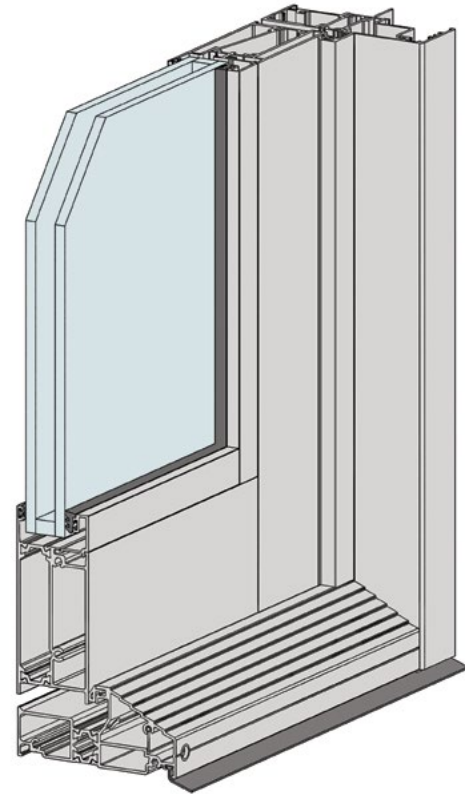

All of the important features are shown in full colour at: www.specifyaws.com.au

Series 729 Thermally Broken Hinged Door

DATE: AUG 20
REPLACES: NOV 09
SCALE: NOT TO SCALE

TYPICAL CONFIGURATIONS

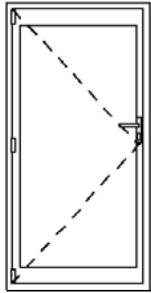

Standard lock
Lever latch set
(key both sides)

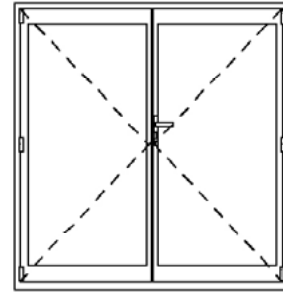
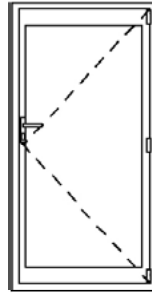

Type. '**LEH**' (external swing)
Type. '**LIH**' (internal swing)

Type. '**REH**' (external swing)
Type. '**RIH**' (internal swing)

Type. '**EHH**' (external swing)
Type. '**IHH**' (internal swing)

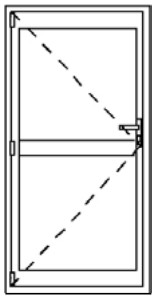

Optional
76mm Chair rail can be applied through door.

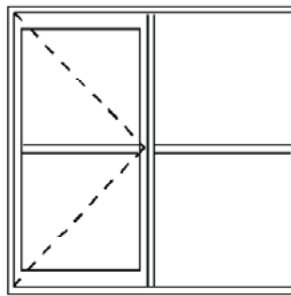

Optional
Sidelight created by coupling Series 726 Fixed light to door frame with thermally broken 'I' coupler.

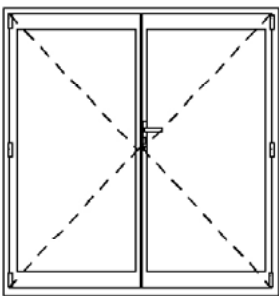

S = Serviceability limit state (deflection = L/150).
U = Ultimate strength limit state (factored yield strength = 104 MPa).

These tables have been calculated using nominal section properties.

A typical assembly has been tested as per the requirements of AS2047,

Ultimate strength rating has been limited to 4500 Pa.

3000 Serviceability ratings were restricted by the maximum water resistance (380Pa) achieved on this product.

Frame Sizes		Ratings		
O/A Height mm	O/A Width mm	Serviceability 1/150	Serviceability 1/180	Ultimate
2100	1600	2300 Pa	1916 Pa	4500 Pa
2100	1800	2066 Pa	1722 Pa	4416 Pa
2200	1600	1979 Pa	1649 Pa	4453 Pa
2200	1800	1775 Pa	1479 Pa	3986 Pa
2300	1600	1715 Pa	1429 Pa	4045 Pa
2300	1800	1536 Pa	1280 Pa	3616 Pa
2400	1600	1497 Pa	1247 Pa	3691 Pa
2400	1800	1339 Pa	1116 Pa	3296 Pa
2500	1600	1314 Pa	1095 Pa	3382 Pa
2500	1800	1175 Pa	979 Pa	3018 Pa
2600	1600	1160 Pa	967 Pa	3111 Pa
2600	1800	1036 Pa	863 Pa	2774 Pa

Wind Ratings (Pa) Meeting stiles.

Series 729 Thermally Broken Hinged Door

DATE: AUG 20
REPLACES: NOV 09
SCALE: NOT TO SCALE

LIMITATIONS

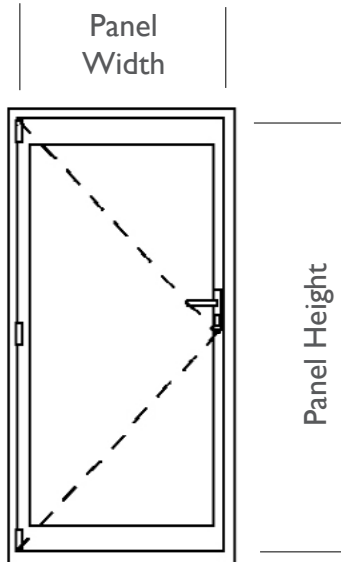

Maximum French Door Panel Sizes with Cast Hinges

Hinge quantity	3. hinges - height less than or equal to 2200mm 4. hinges - height greater than to 2200mm.	
Maximum weight	with 3. hinges	45 kg
	with 4. hinges	60 kg
Maximum panel width	900mm	
Maximum panel height	2600mm - Will vary depending on weight and wind load.	

with Parliament Hinges

Maximum weight	with 3. hinges	50 kg
	with 4. hinges	60 kg
Maximum panel width	900mm	
Maximum panel height	2600mm - Will vary depending on weight and wind load.	

Note: ThermalHEART™ hinged doors are fitted with multi-point locking Lever Compression Locks as standard.



Most of the features on this product can be seen in full colour on our web site:
www.specifyaws.com.au

Series 729 Thermally Broken Hinged Door

DATE: AUG 20
REPLACES: NOV 09
SCALE: NOT TO SCALE

INTERNAL SWING- VERTICAL SECTION INTO BRICK VENEER WALL

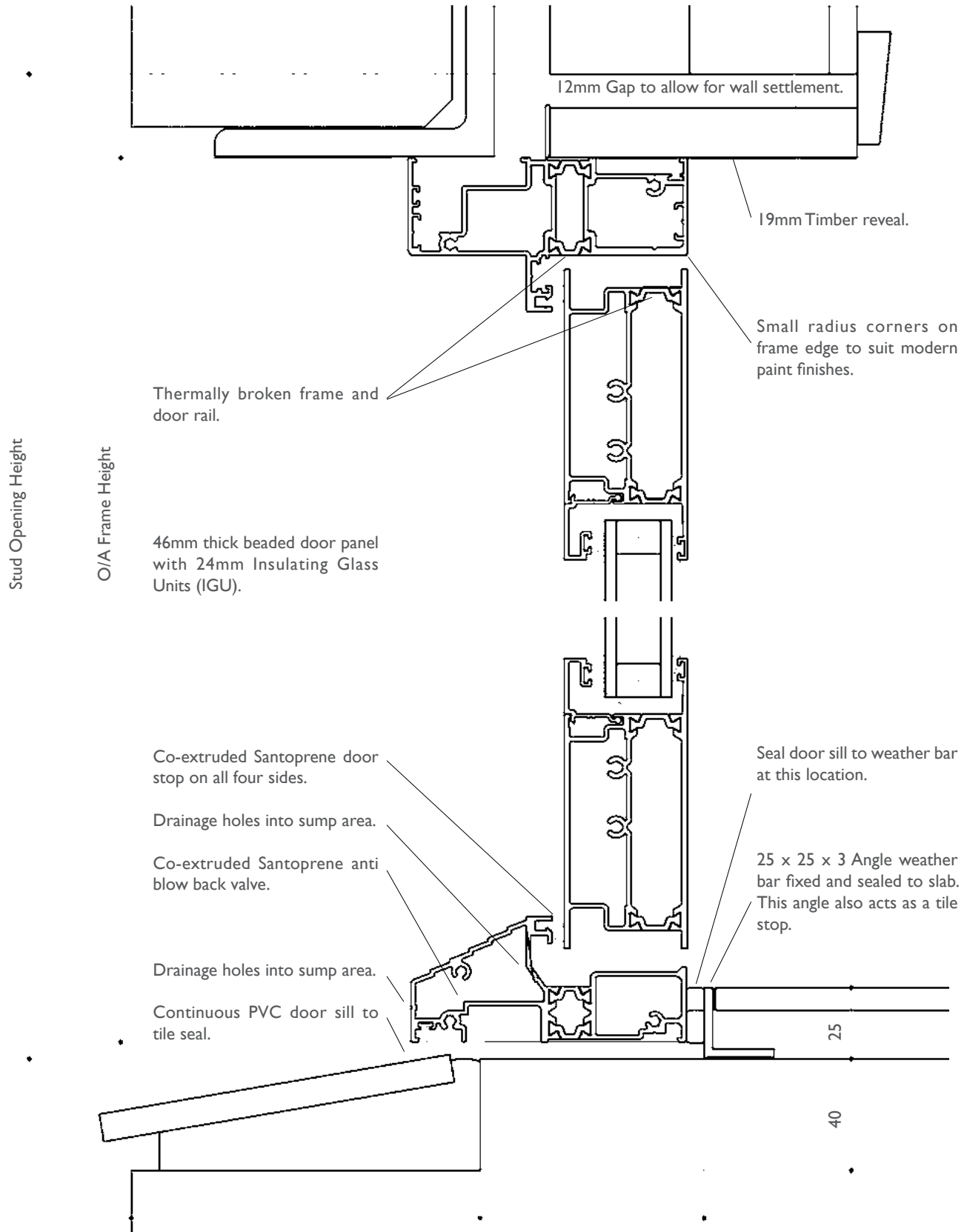

Series 729 Thermally Broken Hinged Door

DATE: AUG 20
REPLACES: NOV 09
SCALE: NOT TO SCALE

INTERNAL SWING FEATURES

The perimeter frame has been designed to match any adjoining fixed or awning frames. The frames are all 100mm wide.

The thermal break is maintained through frame and door panel.

Low line splayed sill / threshold with inbuilt drainage sump.

Internal swing doors can be fitted with custom flydoor adaptor on the outside. This adaptor allows us to secretly fit screen doors in front of the main glass door.

The adaptor spaces the flydoor the right distance away from the glass door panel to suit the custom lever sets (ICON™ and MIRO™).

We have tested this internal swing door for compliance with relevant Australian Standards achieving:
150Pa water resistance.
0.63 air infiltration.

The low air infiltration, makes the product suitable for air conditioned buildings and this is what we need on products designed for thermal transmission reduction.

WERS Rated product.

The extra strong door stiles allow over size door panels to be fabricated, refer Pascal rating tables earlier in these notes.

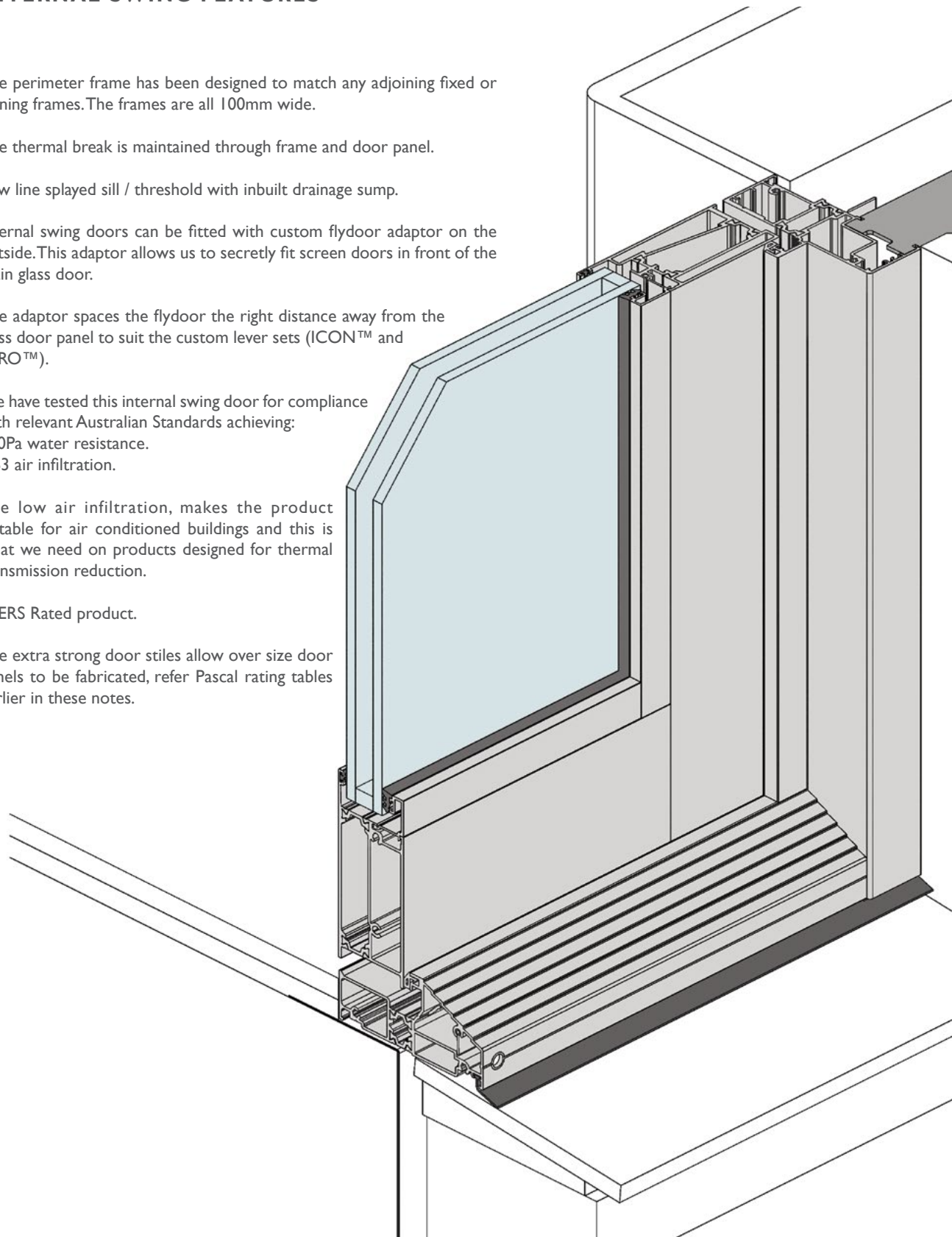

Series 729 Thermally Broken Hinged Door

DATE: AUG 20
REPLACES: NOV 09
SCALE: NOT TO SCALE

INTERNAL SWING - HORIZONTAL SECTION

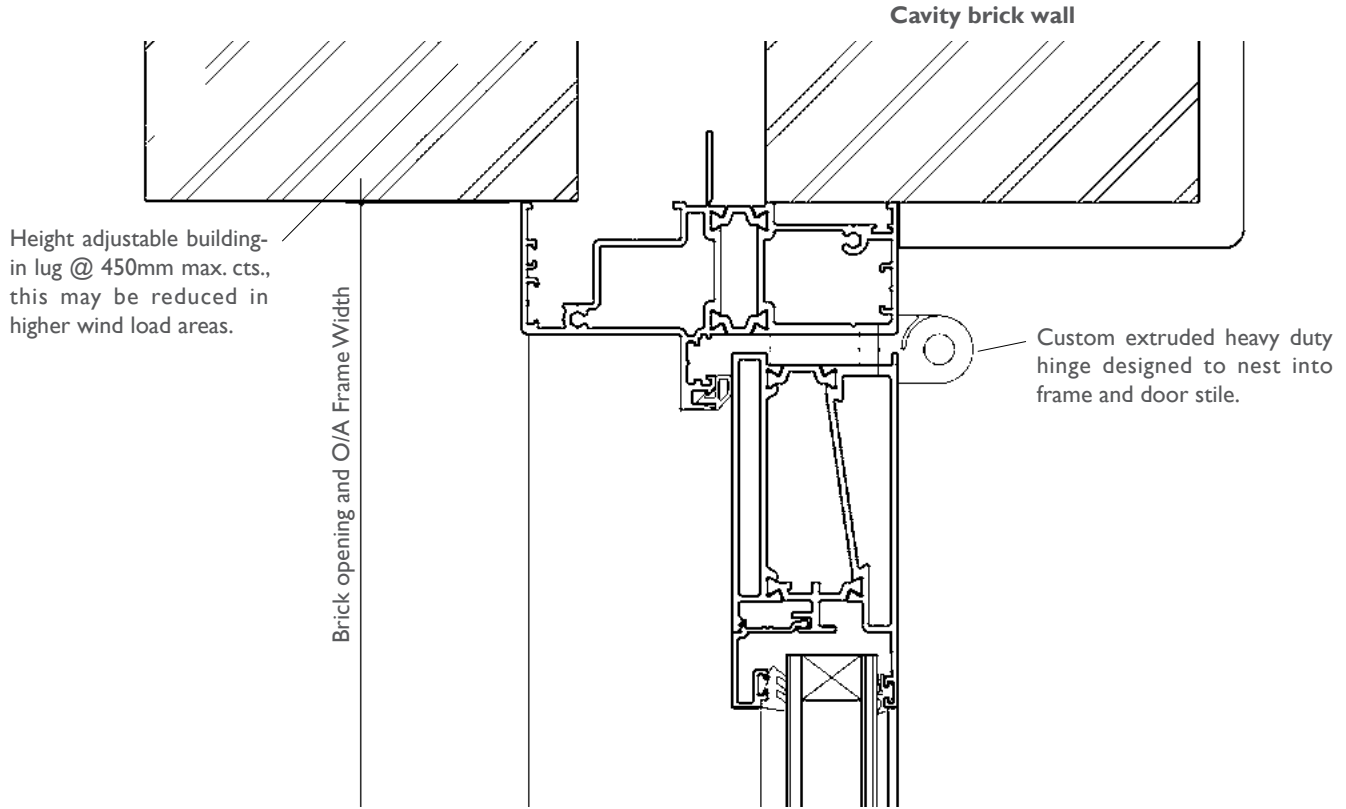

CAD file: DWG
729.HNGE

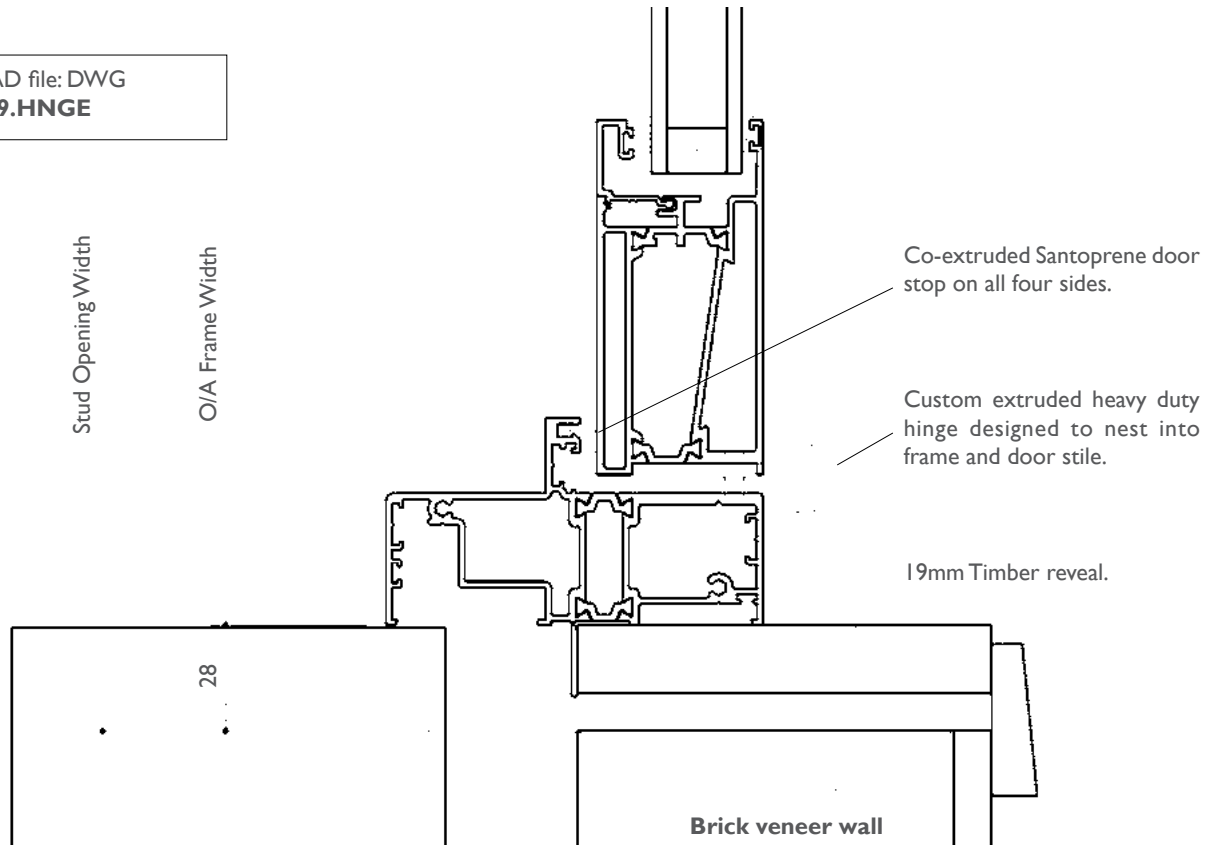

Series 729 Thermally Broken Hinged Door

DATE: AUG 20
REPLACES: NOV 09
SCALE: NOT TO SCALE

HARDWARE MAKES THE DIFFERENCE

Standard Hinge

Designed to allow door panels to open 90° when installed into brick veneer or cavity brick walls.

The hinge leaves nest into the frame and stile removing the need for unsightly shims, maximise strength and to ensure that the gap between frame and stile is maintained.

Hinge frame leaf fixed through reinforced portions of frame and stile with 10# countersunk stainless steel self tapping screws.

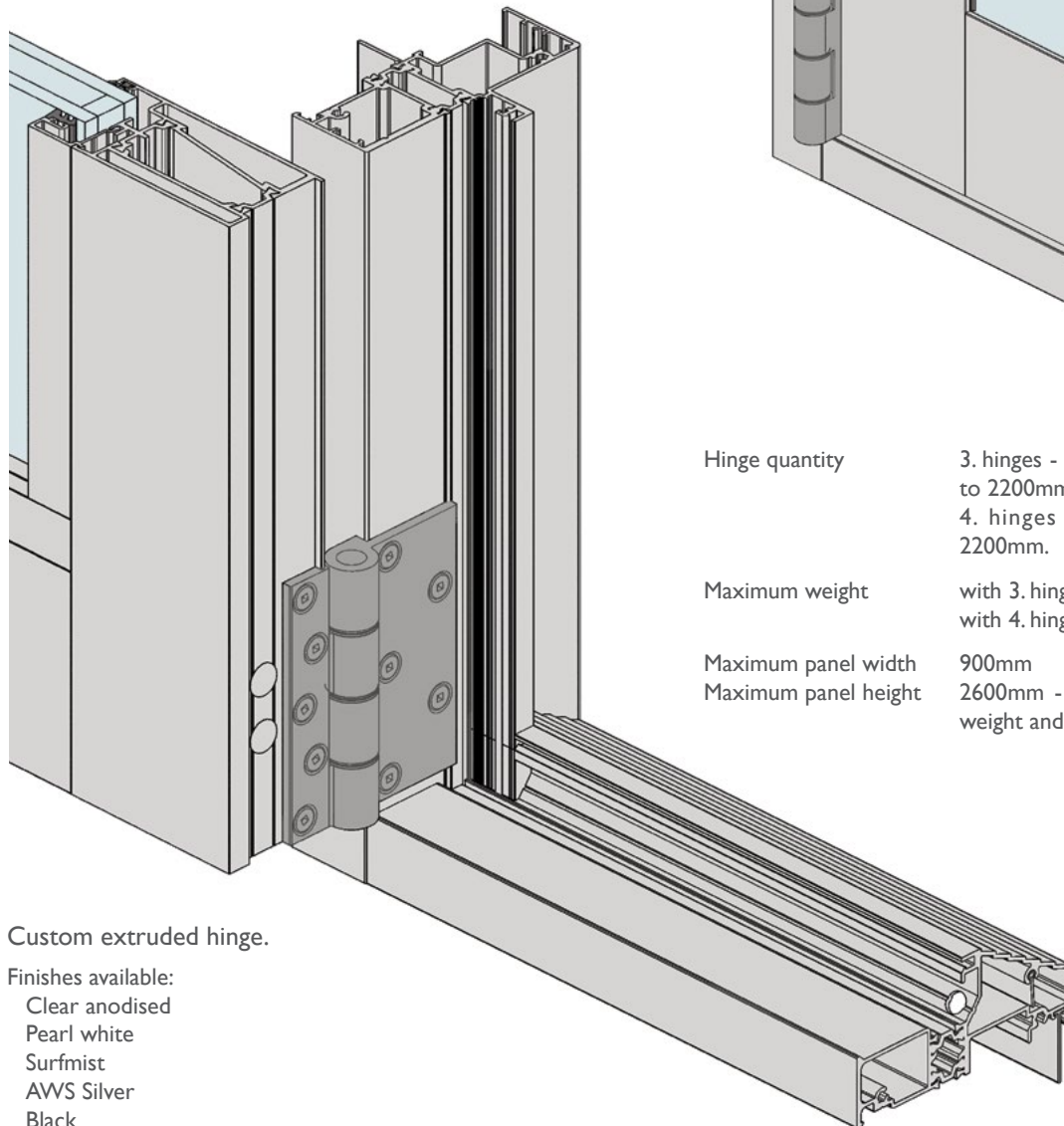
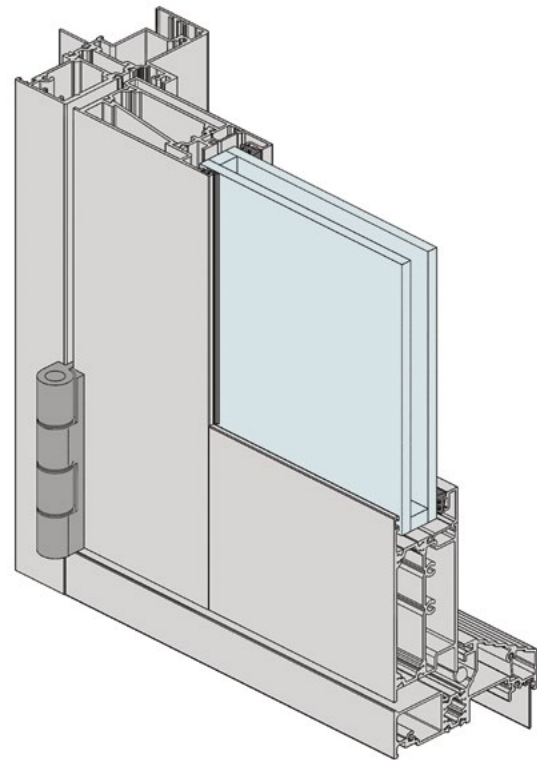

Hinge quantity	3. hinges - height less than or equal to 2200mm 4. hinges - height greater than 2200mm.	
Maximum weight	with 3. hinges	45 kg
	with 4. hinges	60 kg
Maximum panel width	900mm	
Maximum panel height	2600mm - Will vary depending on weight and wind load.	

Custom extruded hinge.

Finishes available:

- Clear anodised
- Pearl white
- Surfmist
- AWS Silver
- Black
- Special paint

Series 729 Thermally Broken Hinged Door

DATE: AUG 20
REPLACES: NOV 09
SCALE: NOT TO SCALE

EXTERNAL SWING - VERTICAL SECTION INTO BRICK VENEER WALL

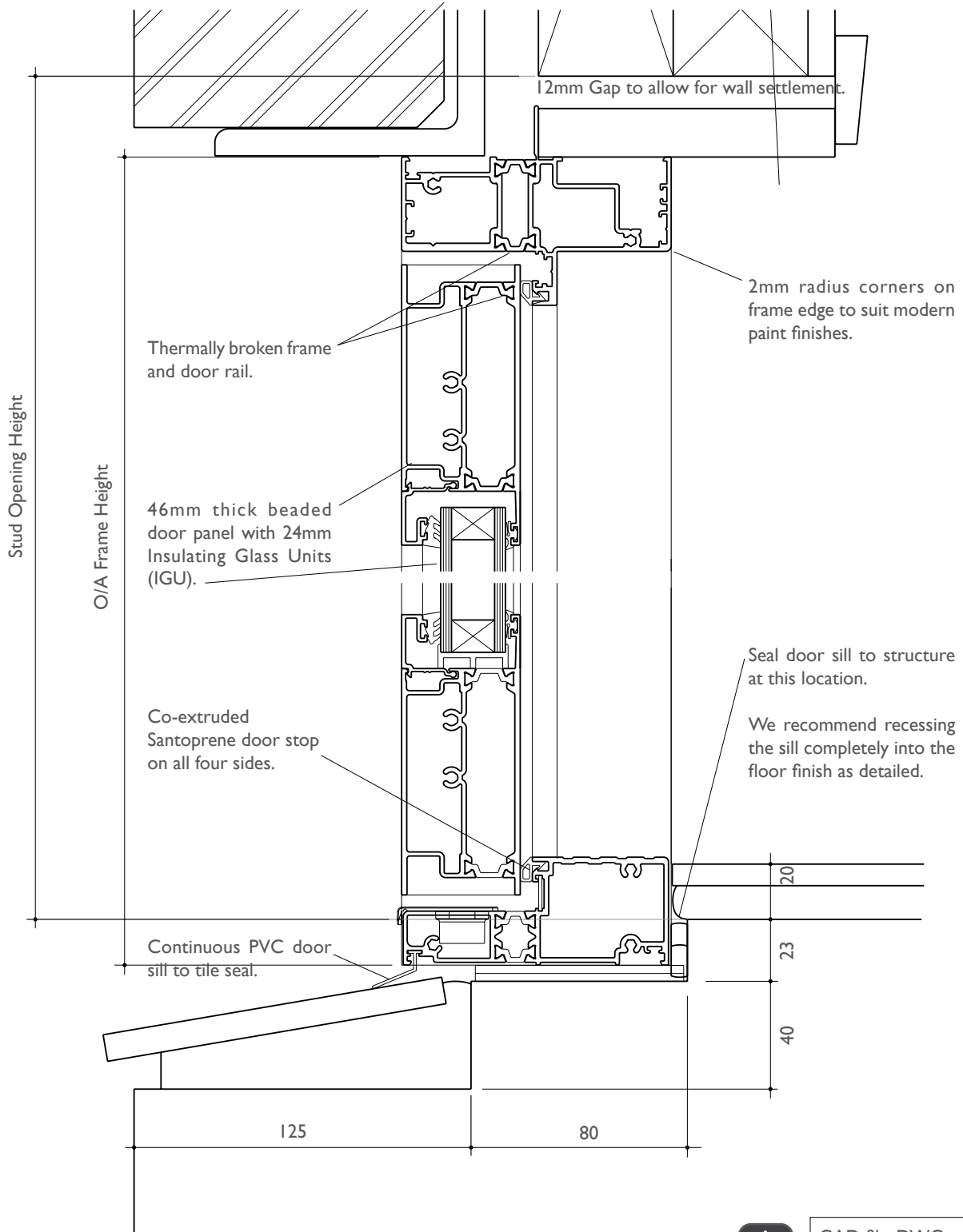

CAD file: DWG
729.HNGE

Series 729 Thermally Broken Hinged Door

DATE: AUG 20
REPLACES: NOV 09
SCALE: NOT TO SCALE

EXTERNAL SWING DOOR - FEATURES

The perimeter frame has been designed to match adjoining ThermalHEART™ bi-fold, sliding or awning frames. The frames are all 100mm wide.

The thermal break is maintained through frame and door panel.

Full perimeter high performance frame.

We have tested this external swing door for compliance with relevant Australian Standards achieving:
380Pa water resistance.
0.63 air infiltration.

The low air infiltration, makes the product suitable for air conditioned buildings and this is what we need on products designed for thermal transmission reduction.

The significantly higher water resistance number makes this door ideal for exposed locations.

WERS rated product.

The extra strong door stiles allow over size door panels to be fabricated, refer Pascal rating tables earlier in these notes.

We recommend that the sill is completely recessed into the floor.

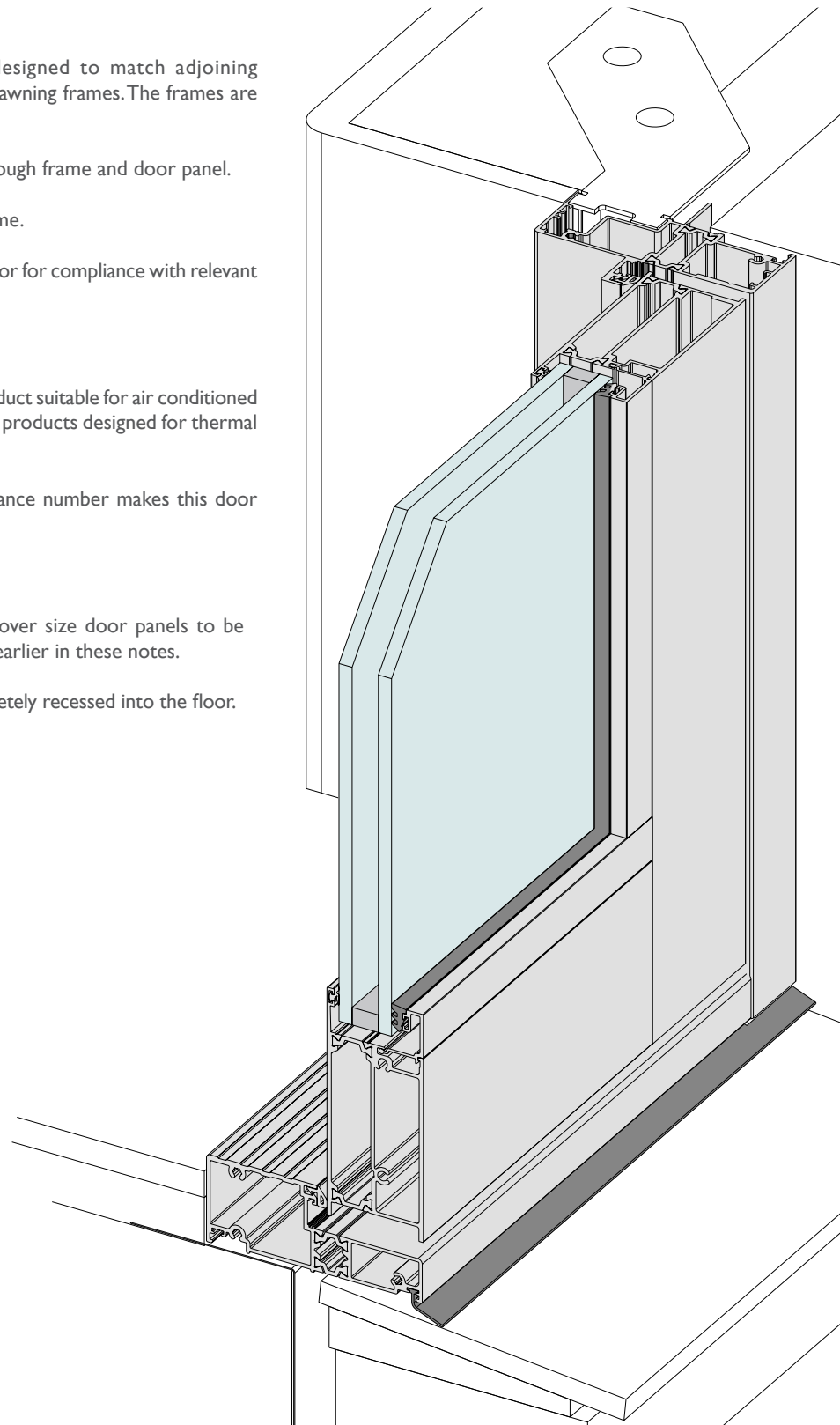

Series 729 Thermally Broken Hinged Door

DATE: AUG 20
REPLACES: NOV 09
SCALE: NOT TO SCALE

EXTERNAL SWING - HORIZONTAL SECTION

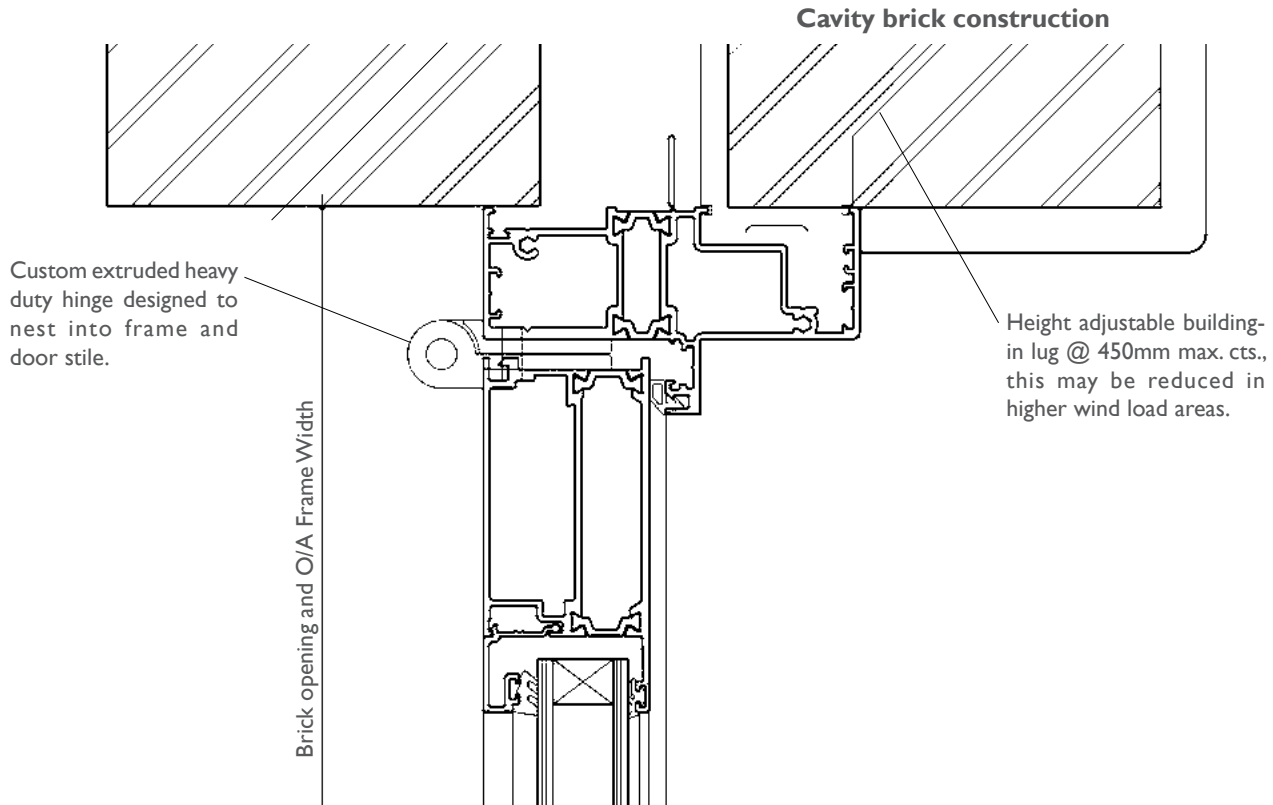

CAD file: DWG
729.HNGE

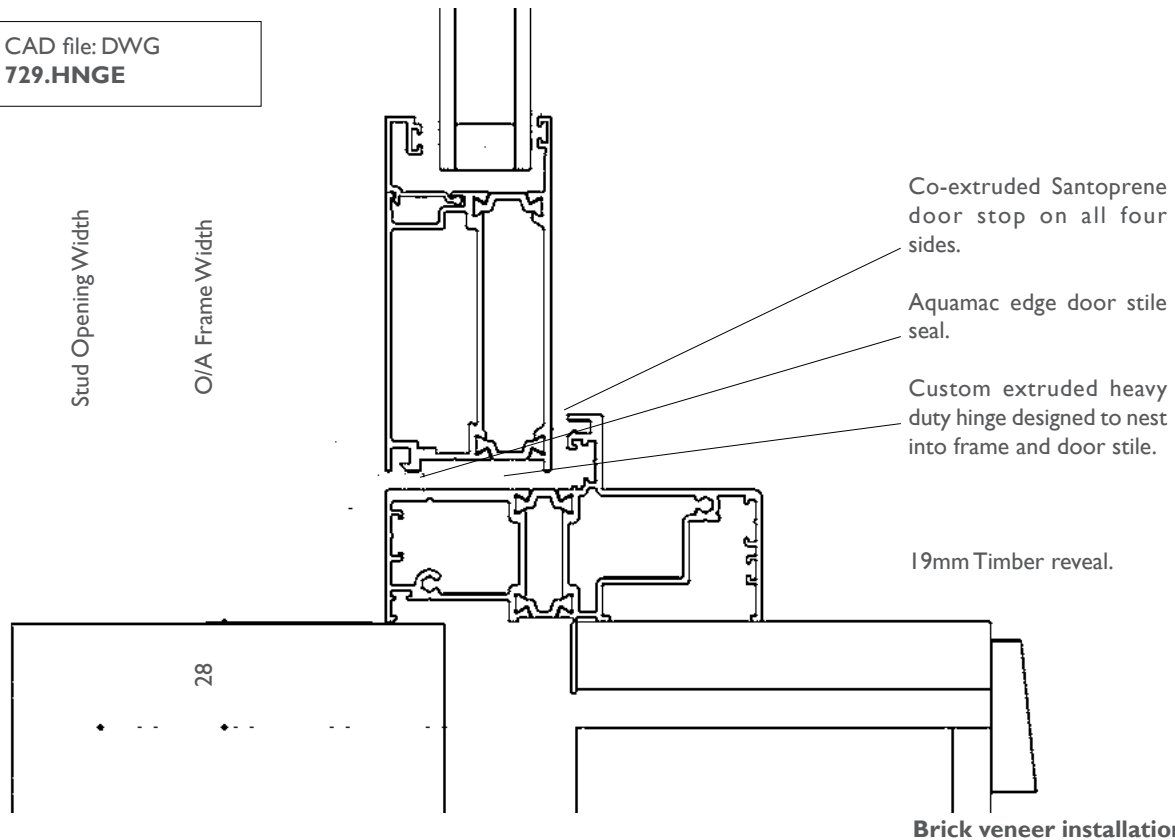

Series 729 Thermally Broken Hinged Door

DATE: AUG 20
REPLACES: NOV 09
SCALE: NOT TO SCALE

HIGHLIGHT COUPLER

Highlight Couplers

We have thermally broken couplers that will join awning frame to hinged, bi-fold or sliding doors as shown below.

Typical strength examples:

With an awning frame 600mm high over a door 2400mm high by 3600mm wide
Standard coupler 72240 would rate 1618Pa Serviceability (1/150) 2688Pa Ultimate.
Heavy coupler 72241 would rate 2529Pa Serviceability (1/150) 4688Pa Ultimate.
Extra Heavy coupler 72242 would rate 3333Pa Serviceability (1/150) 5000Pa Ultimate.

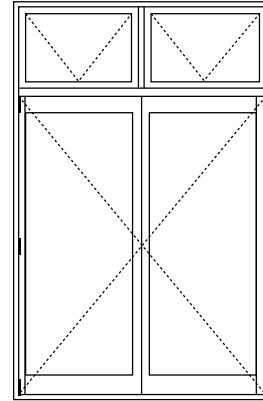

From this you can see that the standard coupler would suit most projects and the heavy coupler would get used on wider bi-fold or sliding doors.

Awning highlight

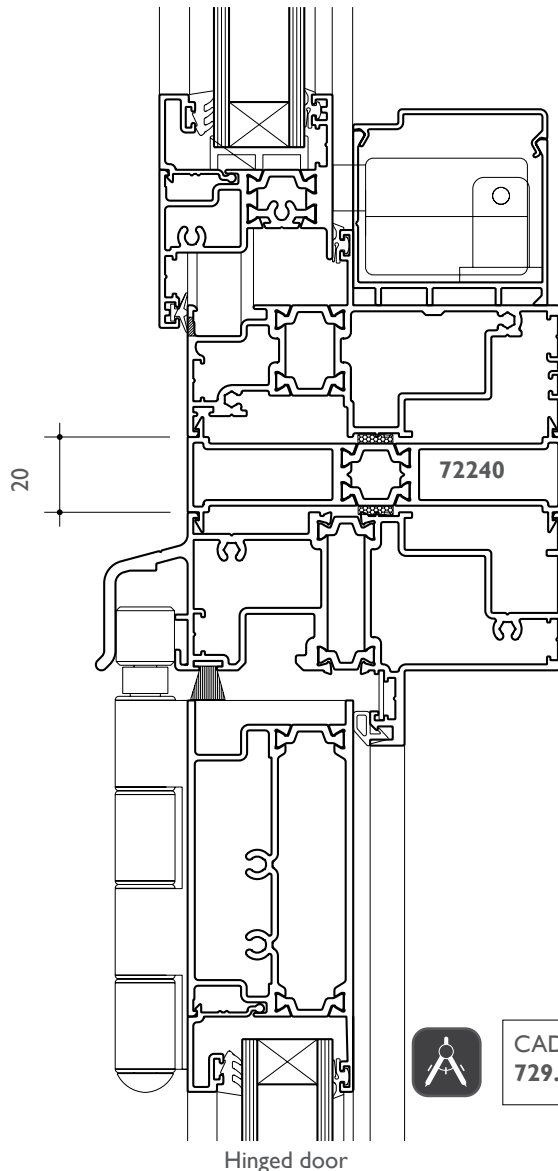

O/A Frame Width mm	Door Lowlight mm	Window Highlight mm	Service 1/150	Service 1/180	Ultimate
2400	2100	600	3333	3333	5000
2700	2100	600	3333	3333	5000
3000	2100	600	2899	2620	4348
3300	2100	600	2295	1913	3502
3600	2100	600	1730	1442	2888
3900	2100	600	1339	1115	2425
4200	2100	600	1058	881	2067
2400	2400	600	3333	3333	5000
2700	2400	600	3333	3333	5000
3000	2400	600	2746	2494	4118
3300	2400	600	2162	1802	3284
3600	2400	600	1618	1348	2688
3900	2400	600	1244	1037	2245
4200	2400	600	979	815	1905
2400	2700	600	3333	3333	5000
2700	2700	600	3333	3333	5000
3000	2700	600	2657	2422	3985
3300	2700	600	2075	1729	3137
3600	2700	600	1538	1281	2544
3900	2700	600	1174	979	2110
4200	2700	600	919	766	1782



CAD file: DWG
729.HNGE

Series 729 Thermally Broken Hinged Door

DATE: AUG 20
REPLACES: NOV 09
SCALE: NOT TO SCALE

OPTIONAL SCREEN DOOR EXTENDER

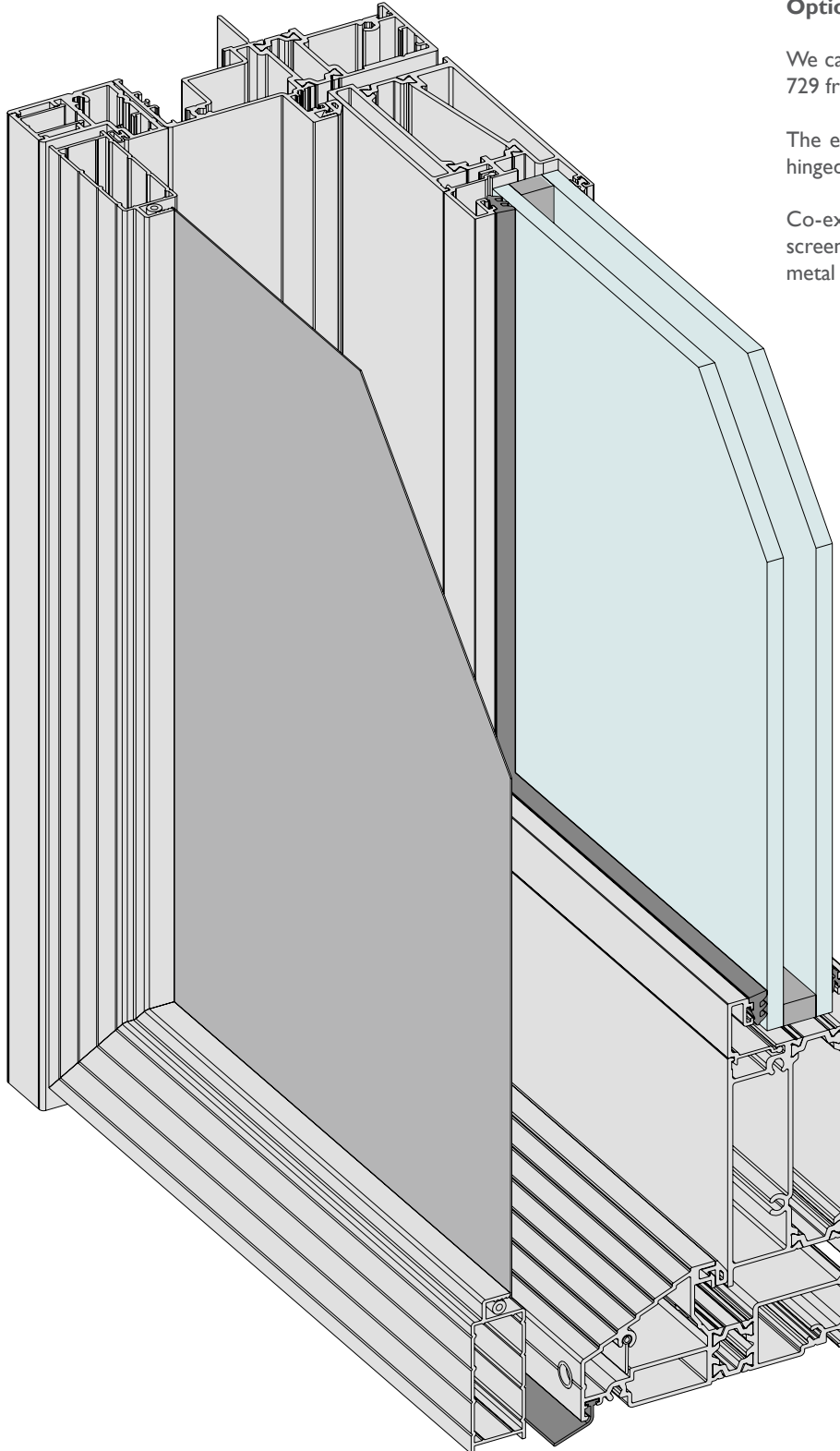

Optional Screen Door Extender

We can secretly fit a flydoor extender to Series 729 frame as detailed on this page.

The extender is rebated to accept 19mm thick hinged flydoor.

Co-extruded Santoprene bulb seal keeps the screen door off the extender frame – prevents metal to metal contact.

Series 729 Thermally Broken Hinged Door

DATE: AUG 20
REPLACES: NOV 09
SCALE: NOT TO SCALE

HARDWARE MAKES THE DIFFERENCE

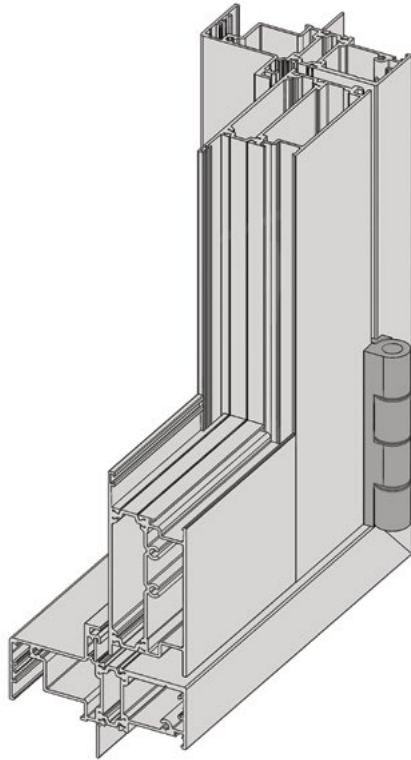

Standard Hinge

Designed to allow door panels to open 90° when installed into cavity brick or brick veneer walls.

The hinge leaves nest into the frame and stile removing the need for unsightly shims, maximise strength and to ensure that the gap between frame and stile is maintained.

Hinge frame leaf fixed through reinforced portions of frame and stile with 10# countersunk stainless steel self tapping screws.

Hinge quantity	3. hinges - height less than or equal to 2200mm 4. hinges - height greater than 2200mm.	
Maximum weight	with 3. hinges	45 kg
	with 4. hinges	60 kg
Maximum panel width	900mm	
Maximum panel height	2600mm - Will vary depending on weight and wind load.	

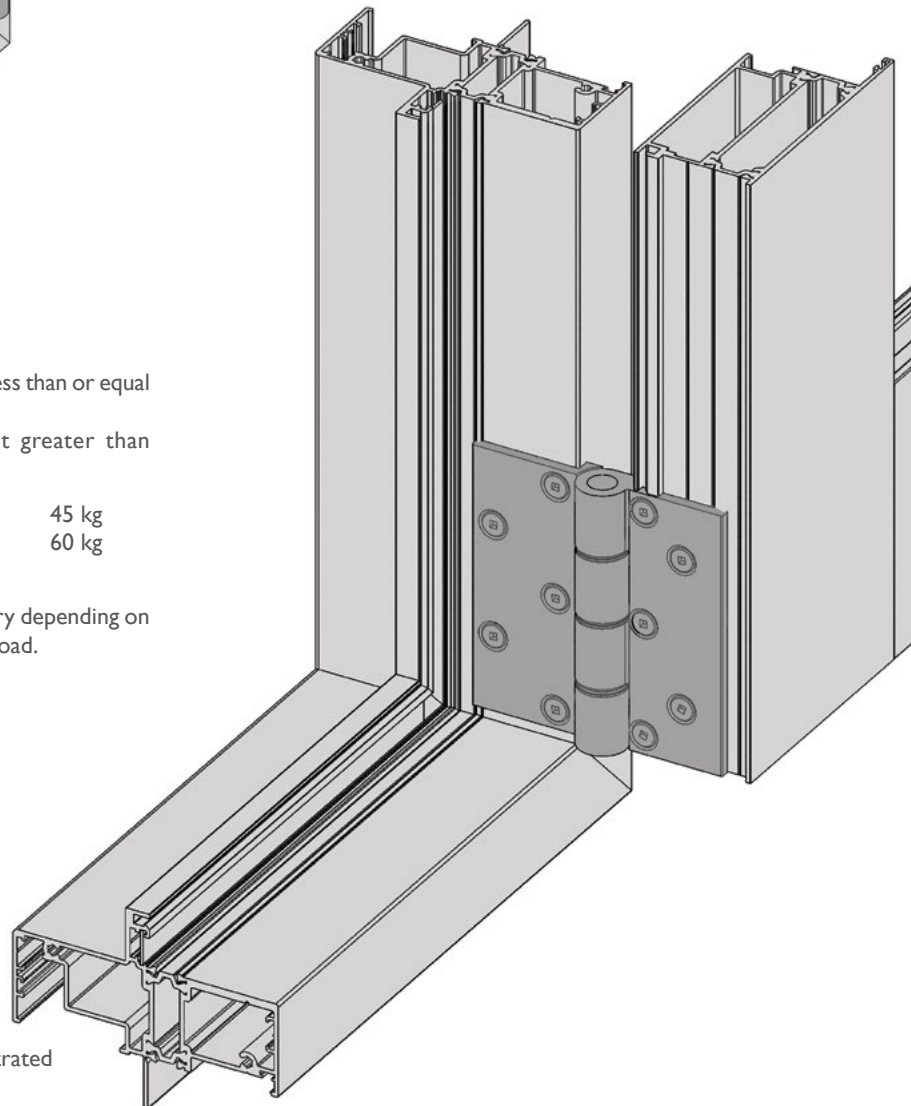

Alternative 72221 sill illustrated

Series 729 Thermally Broken Hinged Door

DATE: AUG 20
REPLACES: NOV 09
SCALE: NOT TO SCALE

HARDWARE MAKES THE DIFFERENCE

Parliament Hinge

Designed to allow door panels to open 180° and lay back against the wall as detailed.

Hinge fixed on two planes to both frame and stile with 10# countersunk stainless steel self tapping screws.

The hinge leaves nest into the frame and stile removing the need for unsightly shims, maximise strength and to ensure that the gap between frame and stile is maintained.

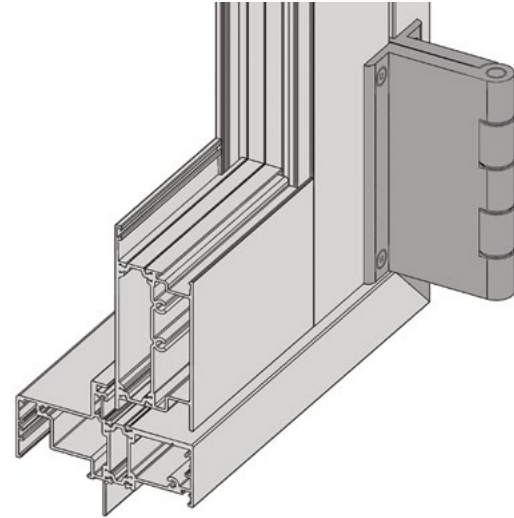

Frame thickened at hinge fixing location

Custom extruded hinge.

- Finishes available:
- Clear anodised
 - Pearl white
 - Black
 - AWS Silver
 - Special paint

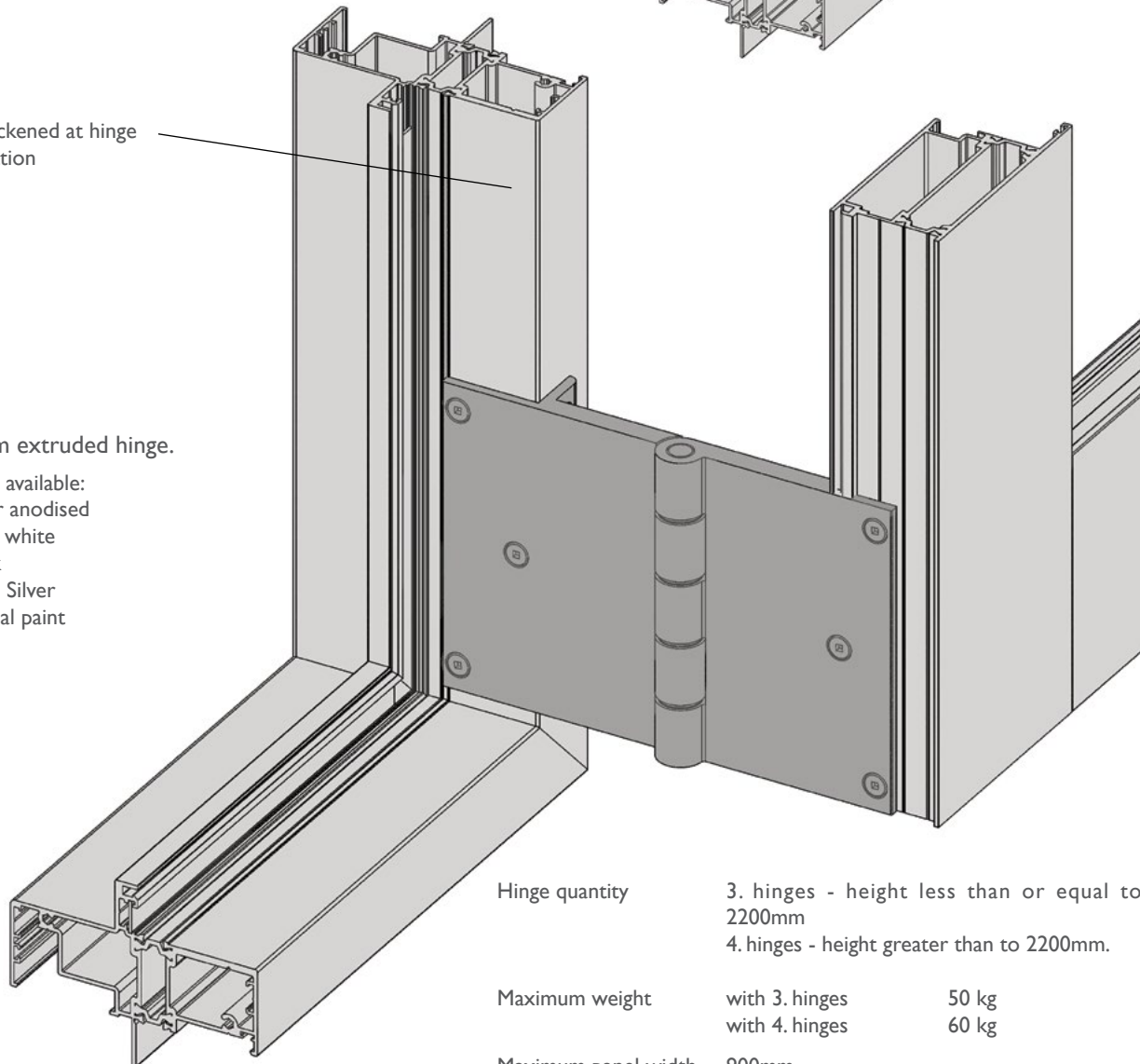

Alternative 7221 sill illustrated

Hinge quantity	3. hinges - height less than or equal to 2200mm 4. hinges - height greater than to 2200mm.	
Maximum weight	with 3. hinges	50 kg
	with 4. hinges	60 kg
Maximum panel width	900mm	
Maximum panel height	2600mm - Will vary depending on weight and wind load.	

Series 729 Thermally Broken Hinged Door

DATE: AUG 20
REPLACES: NOV 09
SCALE: NOT TO SCALE

HARDWARE MAKES THE DIFFERENCE

Standard **ICON™**

Lever Compression Lock

Finishes available:

- 316 Stainless steel

Notes:

Four point locking has the centre latch tongue and throw bolt plus shoot bolts top and bottom.

To activate the lever compression (multi-point locking) feature turn the internal lever handle vertical, this activates the central locking tongue and pushes the shoot bolts into head and sill keeper.

Turning the key locks the central bolt and the top and bottom shoot bolts into position.

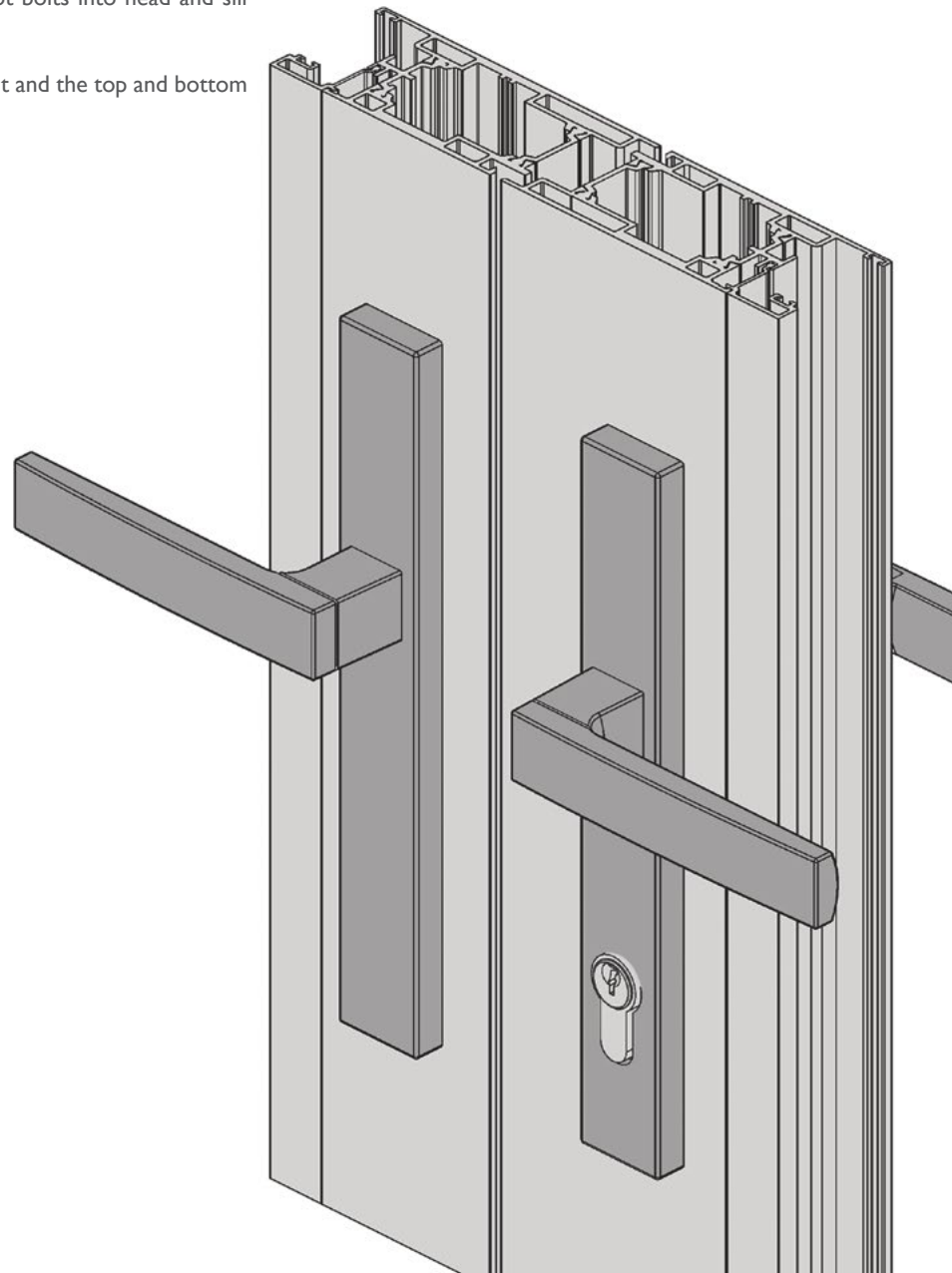

Series 729 Thermally Broken Hinged Door

DATE: AUG 20
 REPLACES: NOV 09
 SCALE: NOT TO SCALE

HARDWARE MAKES THE DIFFERENCE

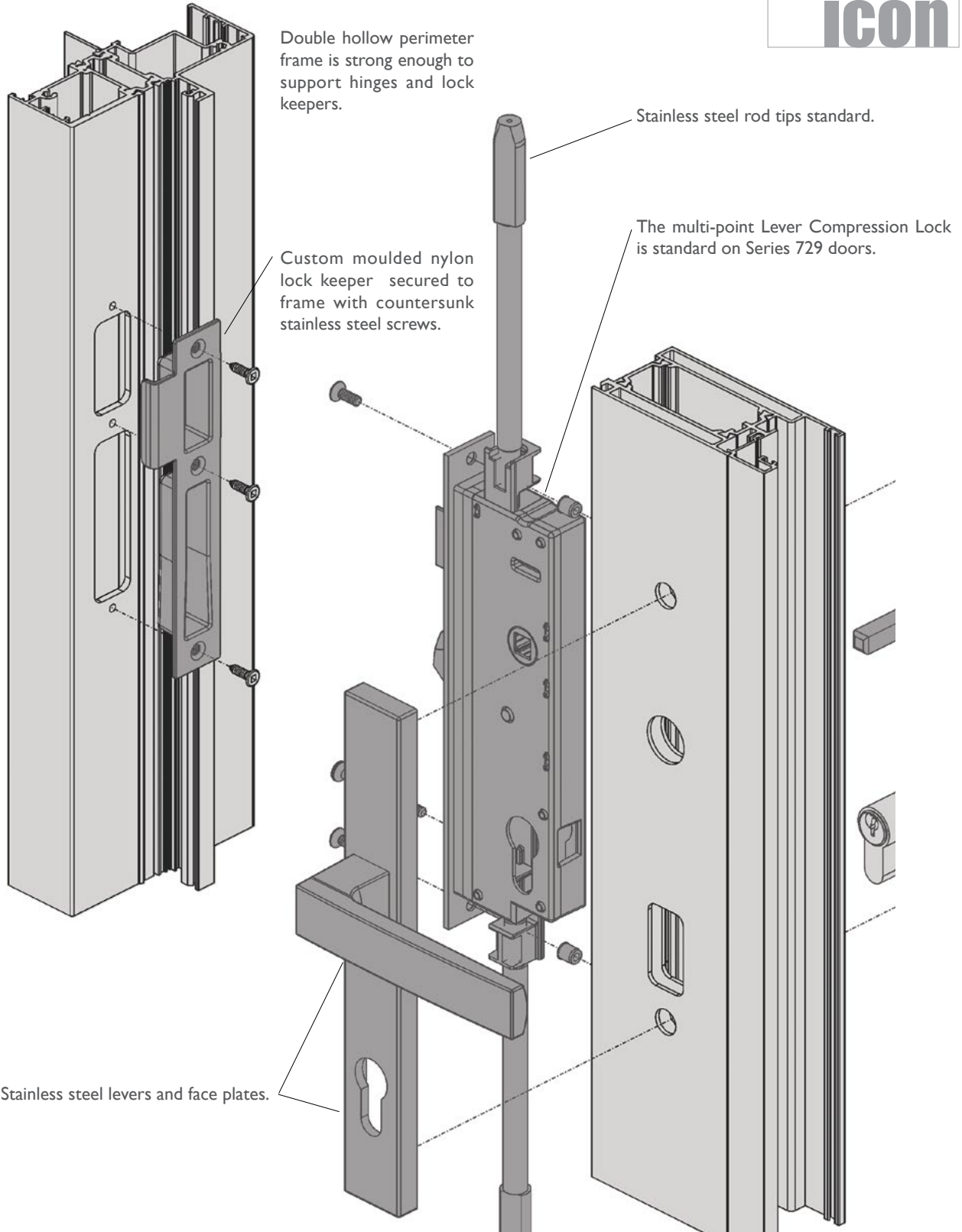

Series 729 Thermally Broken Hinged Door

DATE: AUG 20
REPLACES: NOV 09
SCALE: NOT TO SCALE

HARDWARE MAKES THE DIFFERENCE

ANDO and MIRO hinged door locks are also available.

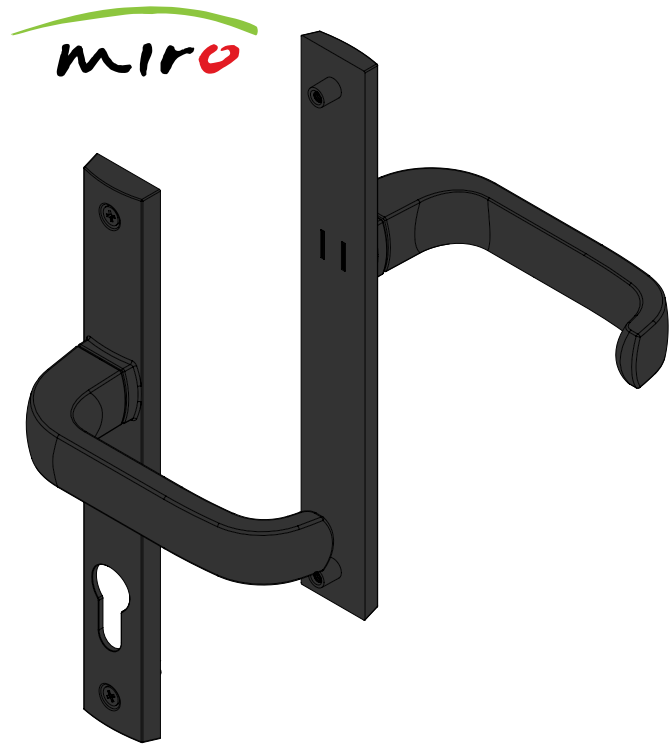
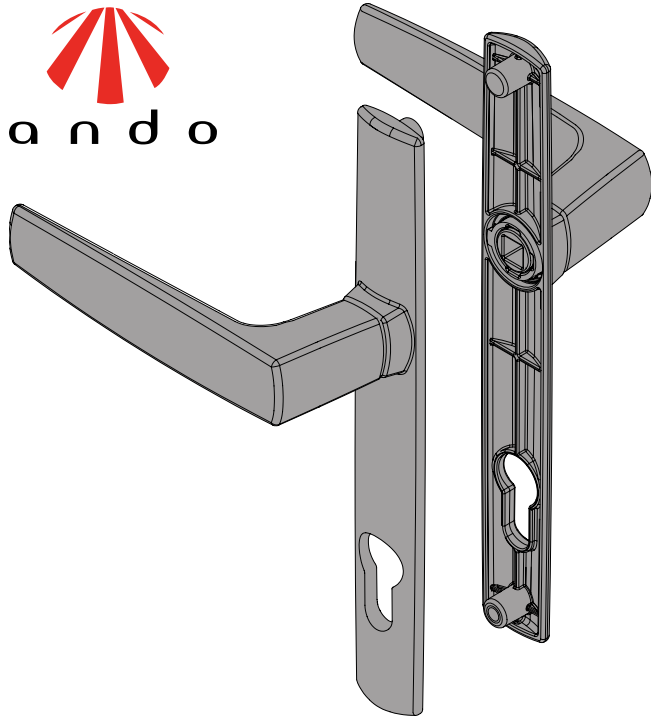

Series 729 Thermally Broken Hinged Door

DATE: AWS 09
 REPLACES: NOV 09
 SCALE: NOT TO SCALE

HARDWARE MAKES THE DIFFERENCE

The custom bolt guides ensure that shoot bolts strike the keeper in the right location. This keeps the doors at the right tension against door to frame perimeter seals.

Custom moulded nylon keepers.

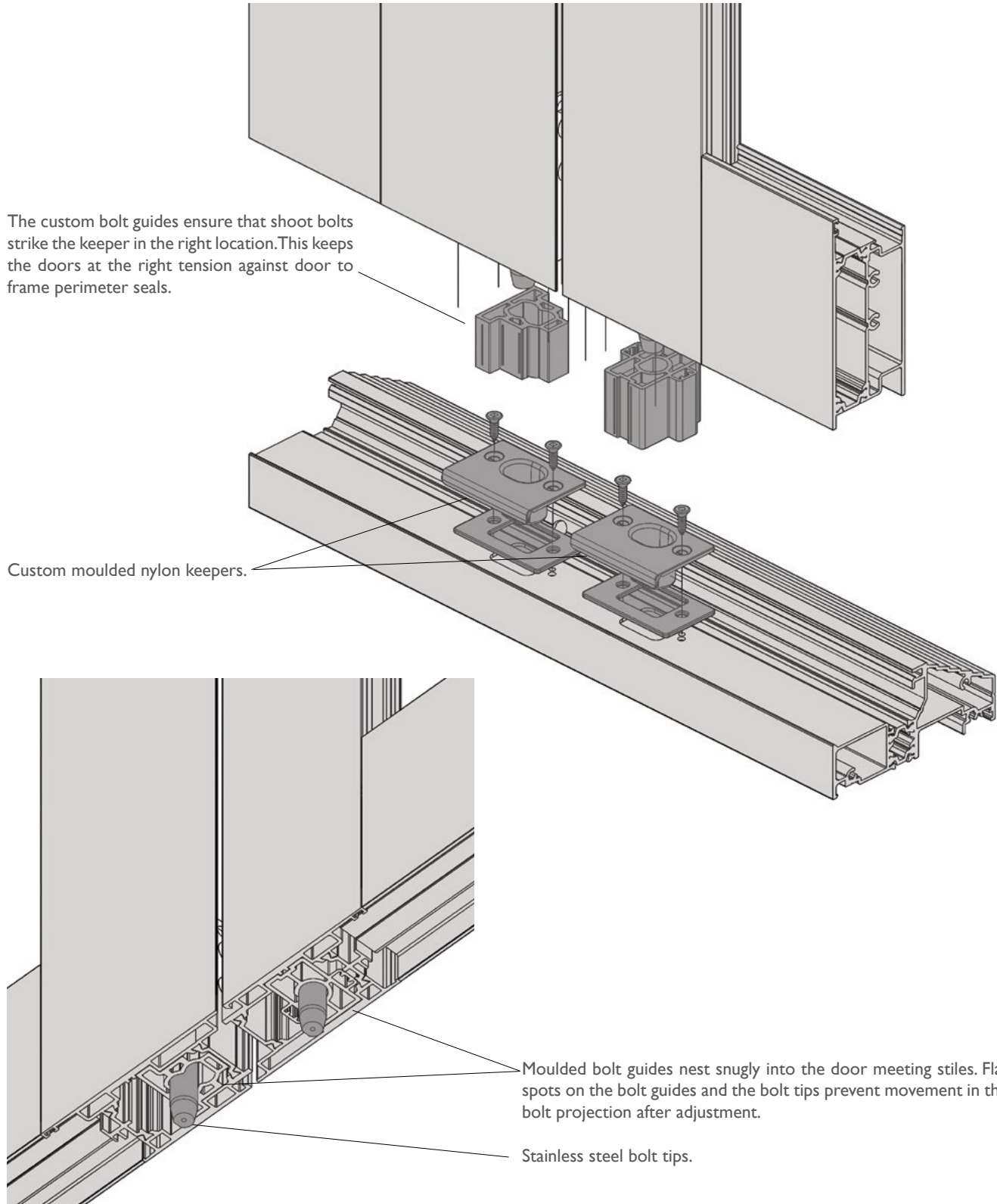

Moulded bolt guides nest snugly into the door meeting stiles. Flat spots on the bolt guides and the bolt tips prevent movement in the bolt projection after adjustment.

Stainless steel bolt tips.

Series 729 Thermally Broken Hinged Door

DATE: AUG 20
REPLACES: NOV 09
SCALE: NOT TO SCALE

TYPICAL VERTICAL CROSS SECTION - CENTOR SCREEN

MAXIMUM STANDARD WEAVE SCREEN FRAME HEIGHT

Standard Weave mesh	3200mm
Tight Weave mesh	3200mm
Air Weave mesh	3200mm
Boston Blockout	3002mm
Boston Light-filtering	3002mm
Tuscany Blockout	3002mm
Tuscany Light-filtering	3002mm
Sunfilter	3200mm

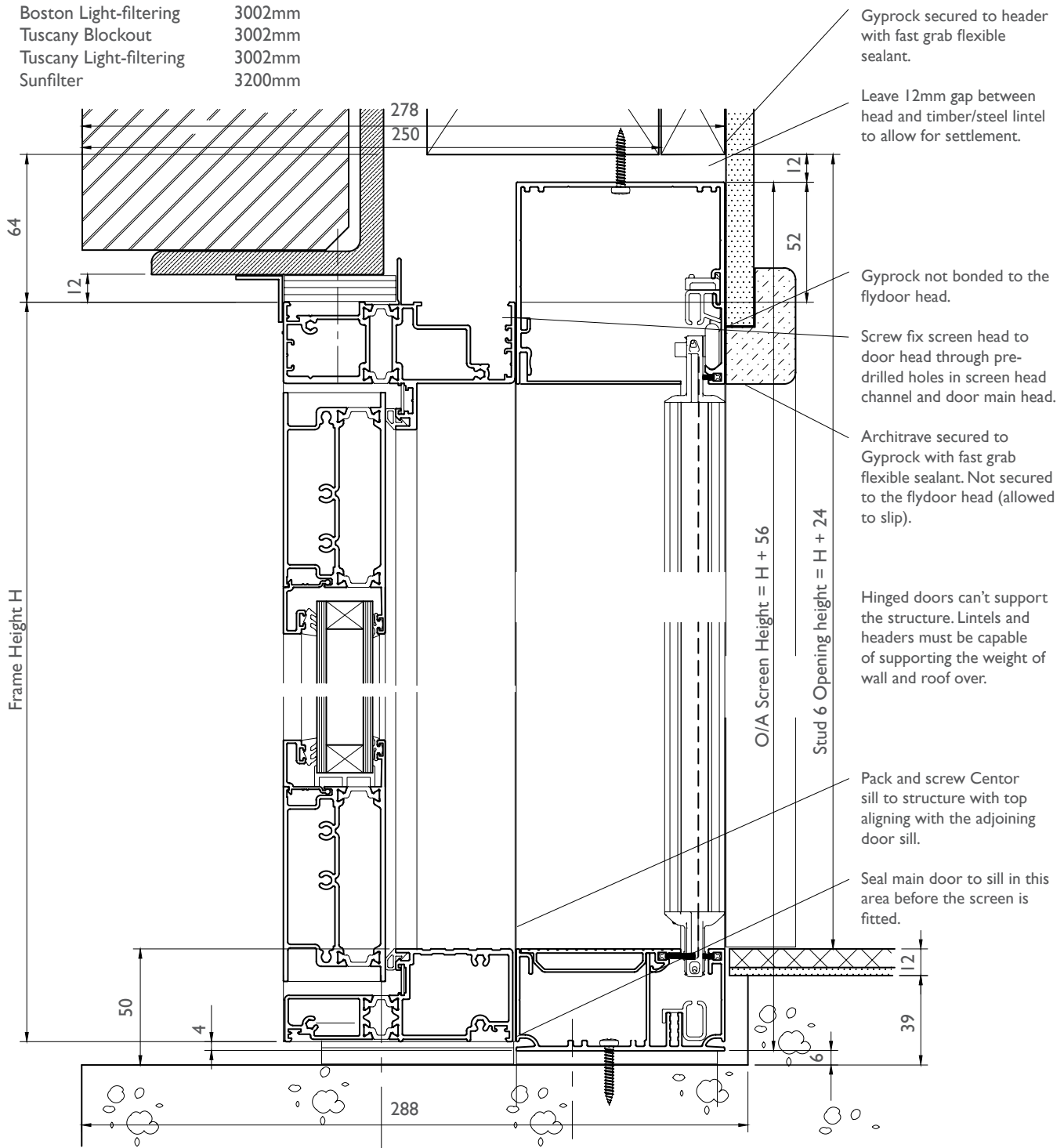

Series 729 Thermally Broken Hinged Door

DATE: AUG 20
REPLACES: NOV 09
SCALE: NOT TO SCALE

TYPICAL HORIZONTAL CROSS SECTION - CENTOR SCREEN 278

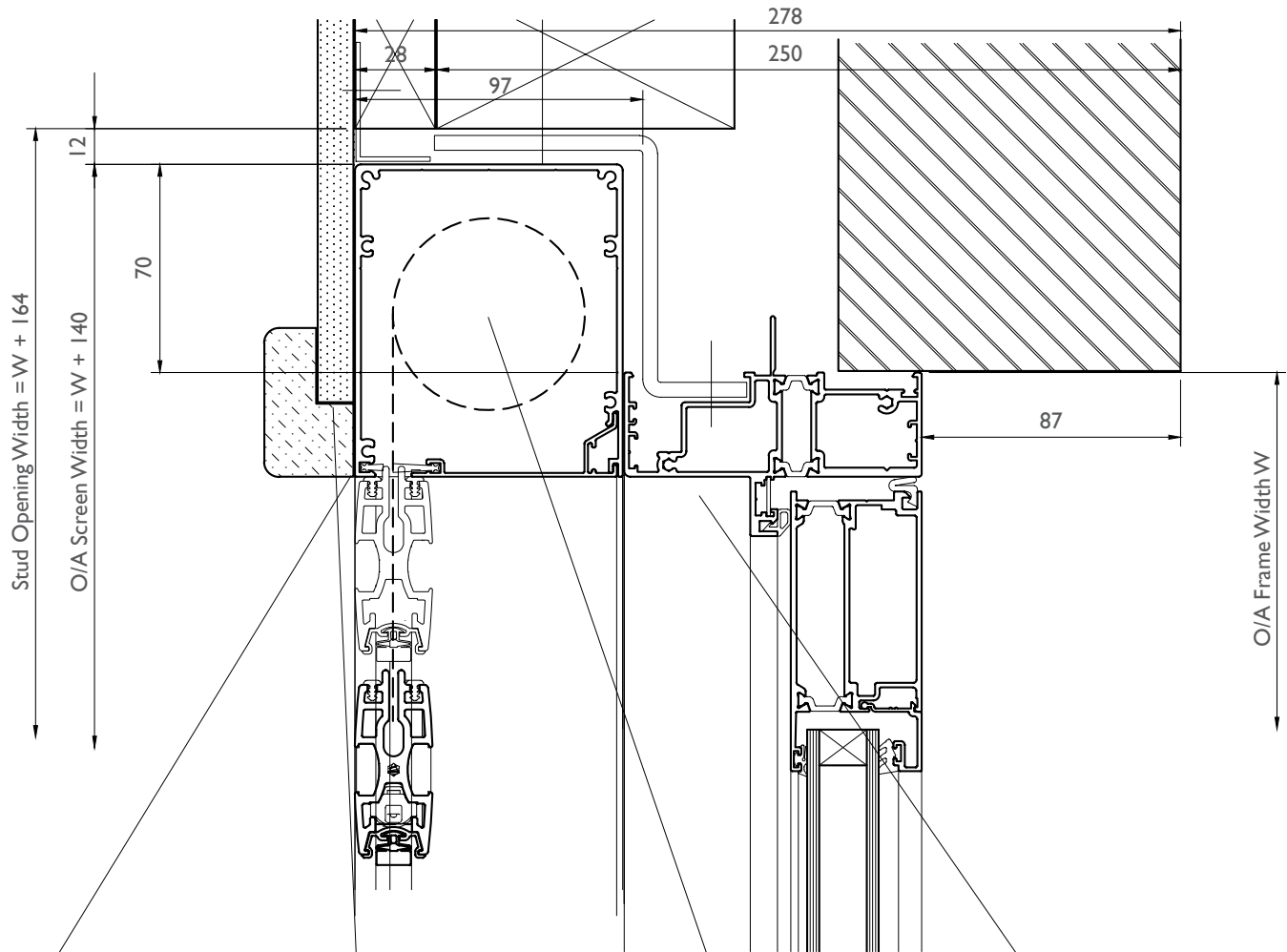

Centor jamb secured to wall and door frame with aluminium lugs and double sided tape, refer Centor installation details.

Timber moulding and Gyprock secured to flydoor jamb with fast grab flexible sealant

Don't screw fix architrave or wall lining into the Centor jamb box as this could damage the screening.

75mm wide 5mm thick galvanised mild steel building-in lugs @ 450mm max. cts., by fabricator.

Important Note:

The wall is 278mm thick, excluding the internal lining. It would be possible to fit this door with S4 screen into 250mm thick wall, but the door frame would have to move forward by 28mm and nailing fin would have to be **removed**.